

Audio Aid: Tube Amp Mods

By Bruce S. Kasprzyk Sr.

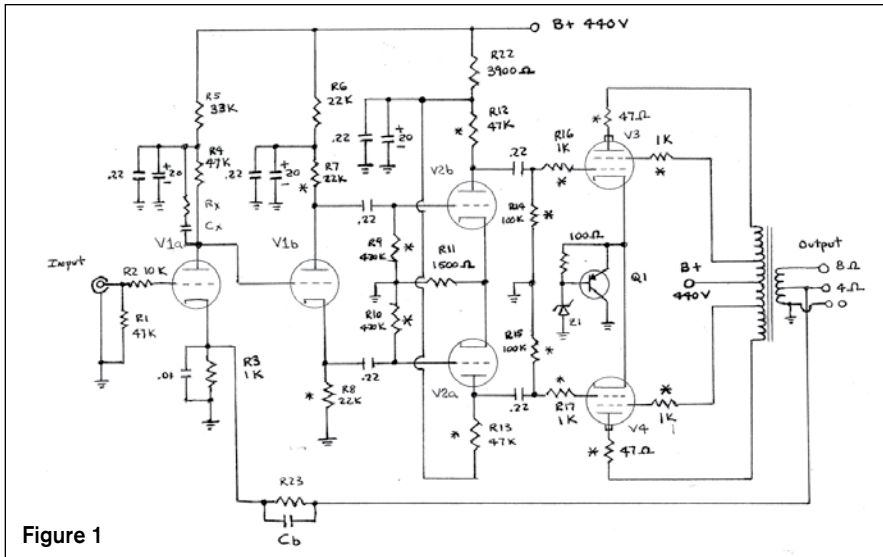

Figure 1

As a longtime reader of *audioXpress*, I look forward to each issue. Of special interest was an article in May 2009 on the Stereomatic 602S amplifier.

First, I would like to compliment John Badalamenti on his article, the excellent quality of construction, and superb workmanship as displayed in the pictures. The Williamson circuit topology is a very good time-tested approach, and over many years has lent itself to justifiable improvement. After reading the article and studying the schematic diagram, I have a few suggestions that you may want to consider.

You should note that much of the Williamson circuit is balanced in nature. The chosen value of certain components may not be that critical, but I believe that a close match of corresponding components is important. To facilitate this you should obtain

a pack of resistors of a given value, and find two that most closely match by using an ohmmeter. I denote these matched pairs with an asterisk (*), as in **Fig. 1**.

Second, one of the themes in the article is instability. A few suggestions to help in that area are as follows:

A. Add plate stopper resistors. Use one 33 to 68Ω 2W carbon resistor in each of the plate leads of the 807s. You should solder the resistor in as close to the plate cap as possible. Then use some heat shrink to cover up the resistor and the exposed solder connection. This addition may help prevent amplifier runaway, and also eliminate ultrasonic and subsonic parasitic oscillations. Elimination of parasitic oscillations will noticeably—and dare I say drastically—improve the headroom of the amplifier! Your amplifier compo-

nents will run cooler as well. Remember, just because you may not be able to hear or see the effects of something doesn't mean that it is not affecting the performance and stability of your amplifier.

B. Change the values of screen-grid stopper resistors R20 and R21. The value of 100Ω, in my opinion, is far too low for ultralinear operation. Usually, 100Ω resistors are used when the 807s are connected for triode operation. I recommend 1000Ω 1W carbon resistors.

C. Try a value between 47kΩ and 100kΩ for grid resistor R1. I think that 470kΩ is too high a value.

Third, I recommend changing the bias arrangement in the following ways:

1. A value of 1000Ω for R11 is OK, but you may want to try 1200Ω or 1500Ω. It has been suggested that this change to the operating point of V2 reduces distortion and helps with its ability to drive V3 and V4 to higher output levels before distortion.
2. For cathode bias of V3 and V4, I recommend removing R18 and R19, C9 and C10 and replacing with the simple circuit shown in **Figs. 1** and **4**. See that Q1 is a TIP107 Darlington transistor, which comes in a TO-220 package that you can bolt directly to the chassis which is used as a heatsink. Diode Z1 is a 1W (or higher) zener diode selected for proper bias voltage for the 807s. A usual value is 30V, but that can vary depending upon the final operating point of the output tubes.

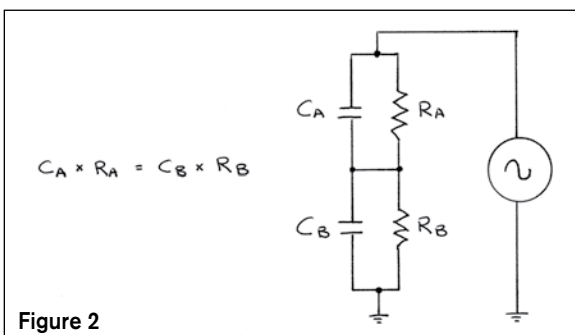

Figure 2

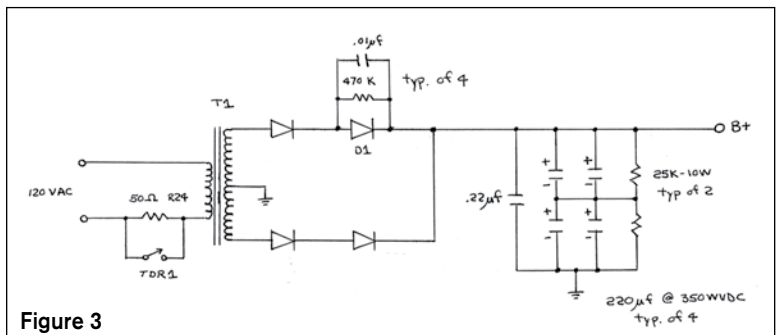

Figure 3

The regulating factor of the zener diode will be improved by the current gain of the transistor. The TIP-107 is rated for 80W dissipation with a current gain of 1K minimum and a voltage rating of 100V DC. You can substitute a TIP-147 if you need higher dissipation. The cathode bias voltage will stay *very* stable with changing plate and screen currents typically found in Class AB amplifiers.

One of the advantages of this circuit is that an effective capacitance of many thousands of microfarads is developed in the cathode circuit, resulting in a deep low end. I have used this circuit for many years with EL34s, 6L6s, 811s, and 805s, all with good results. Whether you use two 807s in push-pull or four in push-pull parallel, the bias voltage will hold rock solid.

Fourth, consider feedback and frequency compensation in the following ways:

- a. Add a frequency compensation network across R4 with a series-connected 270pF silver mica capacitor and 4700Ω ½W carbon resistor. This combination helps to control high-frequency response, and has a turnover frequency of about 125kHz. So it will not cause any audible high-frequency loss but will help attenuate ultrasonic oscillations.
- b. I recommend changing C3 to 0.01μF and keeping R3 at 1000Ω. This combination will be one section of a frequency-compensated voltage divider and part of the overall feedback network.
- c. Feedback resistor R23 seems too high in value. You may prefer to try values between 8.2kΩ and 33kΩ. The value of this resistor will also depend upon which taps are used on the output transformer. Unfortunately, 100kΩ results in very little feedback, only about 1%. The 807 is a good tube but can be prone to oscillation. That is why the plate and grid stoppers are so very important (and should be soldered in as close to the tube as possible).

The basic formula for a frequency-compensated voltage divider is $(R_a)(C_a) = (R_b)(C_b)$. If $R_a = 1000\Omega$

and $C_a = 0.01\mu\text{F}$, and $R_b = 8200\Omega$, then $C_b = 0.0012\mu\text{F}$. Because 0.0012μF is not a standard value, you could use a 0.001μF here. This is shown in **Fig. 2**. Some experimentation in this area is warranted, so try different values of R_b and C_b to obtain different levels of feedback, high-frequency response, and amplifier stability.

Fifth, take a look at the power supply. Decoupling among the low-level stages is important for stability and fidelity. For a star-type circuit, I suggest a 33kΩ, 2W resistor for R5, and a 22k, 2W resistor for R6. I recommend removing R22. Put a 3900Ω, 2W resistor between the B+ and resistors R12 and R13. Then connect C4 at the junction of R12 and this new resistor.

In addition, you should bypass electrolytic capacitors C1, C2, C4, and C17 with 0.22μF, or greater, high-quality audio-grade coupling capacitors of sufficient voltage rating. Also, use high-quality coupling capacitors for C5, C6, C7, and C8. Again, I recommend capacitors such as Solen Fast (or equal), which make a noticeable difference in sound quality throughout the entire audio spectrum. Solens are easily obtainable, and reasonably priced.

You can operate the 807 at a plate voltage of up to 750V DC. The power output will correspondingly rise, so pick an appropriate output transformer to handle the power. By selecting the correct plate to plate load impedance, you can easily obtain 100W output from push-pull parallel 807s.

Try any modifications one at a time, and then listen to the results. The order I suggest is:

1. Change the grid stopper resistors, add

plate stopper resistors.

2. Make power supply and decoupling modifications.
3. Change the V2 cathode bias resistor R11.
4. Install a new cathode bias circuit for V3 and V4.
5. Install the high-quality coupling and bypass capacitors.
6. Improve feedback and stability with R1, R23, C3, and Cb.
7. Install a frequency compensation network across R4, if needed.

Finally—experiment!

Postscript

1. If there were to be major changes in the power supply, I would recommend two items. First, use 3A at 1000V PIV diodes, with suppression capacitors and equalization resistors, for rectification. Second, replace the filter capacitors with series parallel connected 220μF at 350WV DC Ruby capacitors. This will give you more energy storage and “punch” to your audio (**Fig. 3**).

$$\hat{e} = \frac{1}{2} C E^2$$

$$\text{Energy} = (.5) \times (220) \times (10^{-6}) \times (440)^2 = 21.3 \text{ joules}$$

2. Tubes that work well in a Williamson circuit are: 6L6GC, EL34/6CA7, 6550, KT66, KT77, KT88, KT90, 5881, 7591, 7027, 6146, and if you want to try some triodes: 5V811-10.

*Bruce S. Kasprzyk Sr.
Cinnaminson, NJ*

I would like to thank my son, Bruce S. Kasprzyk, a freelance professional recording and mastering engineer with a number of projects to his credit, currently residing in Madison, WI, for his critique and revision of this response. Bruce has constructed a similar amplifier based on 12AU7s and EL34 output tubes.

Bruce S. Kasprzyk Sr. is a degreed electrical engineer, amateur radio operator WA-3JVV, and an audio and music enthusiast for over 40 years. He may be contacted at bskasprzyk@juno.com. **rr**

